

**SHORT WHEEL BASE**

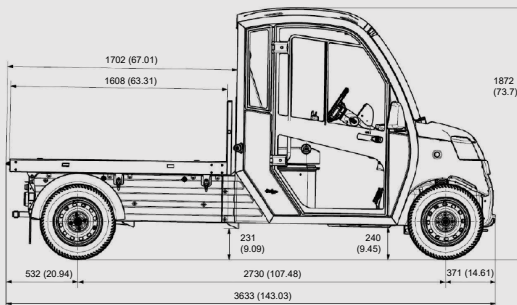
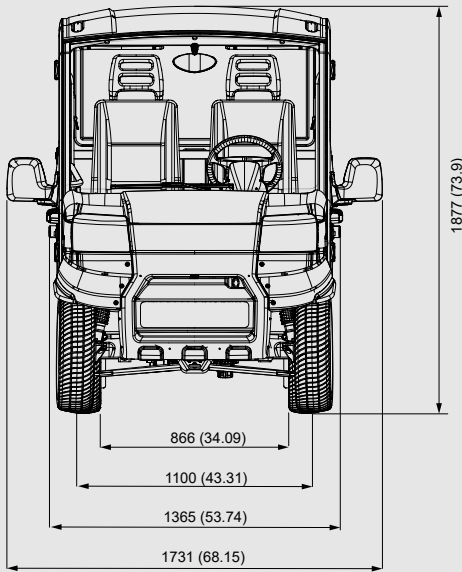

**LONG WHEEL BASE**

	LONG WHEEL BASE	SHORT WHEEL BASE
--	-----------------	------------------

<b>MOTOR</b>	48V High efficient 3-phase AC engine	
<b>NOMINAL POWER</b>	12 kW (16,1 hp)	
<b>PEAK POWER</b>	18,2kW (24,4 hp)	
<b>MAX TORQUE</b>	70 Nm	
<b>MOTOR CONTROLLER</b>	Curtis 450 A	
<b>CHASSIS</b>	Hot dip galvanized steel frame	
<b>BRAKES</b>	Discs front, drums rear	
<b>SUSPENSIONS</b>	Independent coil over	
<b>TIRES</b>	165/70 R13	
<b>TOW LOAD CAPACITY</b>	250 kg	

### PERFORMANCE

<b>TOP SPEED</b>	40 km/h (25 mph)	
<b>OPERATING GRADE</b>	< 20 %	

### MASS

<b>MAX. GROSS PAYLOAD</b>	1 000 kg (2 205 lbs)	500 kg (1 102 lbs)
<b>MASS IN RUNNING ORDER*</b>	550 kg (1 213 lbs)	536 kg (1 182 lbs)
<b>TECHNICALLY PERMISSIBLE MAX. MASS</b>	1 850 kg (4 079 lbs)	1 350 kg (2 976 lbs)

### DIMENSIONS

<b>LENGTH</b>	3 633 mm (143 in)	3 272 mm (129 in)
<b>LENGTH WITH ADDITIONAL CHASSIS EXTENSION</b>	N/A	3 635 mm (143 in)
<b>WIDTH (W/ W.O. MIRRORS)</b>	1 731 mm (68 in) / 1 365 mm (54 in)	1 731 mm (68 in) / 1 365 mm (54 in)
<b>HEIGHT</b>	1 877 mm (74 in)	1 877 mm (74 in)
<b>WHEELBASE</b>	2 730 mm (107 in)	2 130 mm (84 in)
<b>OUTER TURNING RADIUS</b>	4 250 mm (167 in)	3 400 mm (134 in)

### BED OPTIONS

<b>PICKUP BED</b>	1,6 m fixed + tipping	1,25 m fixed + tipping and 1,6 m fixed
<b>VAN BOX</b>	2,1 m <sup>3</sup>	1,6 and 2,1 m <sup>3</sup>

### STANDARD FEATURES

Digital instrument cluster, speed switch, rear lights, rear fog light, secure storage locker, dash storage compartment, automatic parking brake, safety cab, 3 pt seat belts, rear bumper, horn, all season road tyres, bench seat, heated windscreen, wash/wipe pack, mirror pack

### OPTIONAL FEATURES

Lockable cab door, adjustable twin seats, deluxe cab pack, right hand drive, tow ball, cab heater, stereo + USB plug, refrigerator, reverse camera, roof beacon

BATTERY	SHORT & LONG WHEEL BASE				LONG WHEEL BASE ONLY
	<b>CAPACITY</b>	T145 FLA (11,5 kWh)	6 kWh	10,2 kWh	13,6 kWh
<b>VOLTAGE</b>	48 V	51,2 V	51,2 V	51,2 V	51,2 V
<b>WEIGHT</b>	264 kg (582 lbs)	62 kg (137 lbs)	137 kg (302 lbs)	150 kg (331 lbs)	218 kg (481 lbs)
<b>CHARGE TIME</b>	8 hrs	6 hrs	6-8 hrs	8-10 hrs	10+ hrs
<b>RANGE (WLTP)</b>	80 km (50 miles)	55 km (34 miles)	110 km (68 miles)	145 km (90 miles)	205 km (127 miles)

\*battery weight not included